

# Malö 39



# Malö 39



The Malö 39 is handmade. Every one is unique. And handsome. She is built to take you, your family and friends to places whenever you desire, wherever the wind blows.

The Malö 39 sails fast. And easily. She has a powerful rig with a furling genoa and a full battend main falling into Lazy-Jacks. Seakindly lines and 50% ballast make the Malö 39 a seaworthy yacht. Her concept is cruising pure. On deck. And below.



Jede Malö 39 wird von Hand gebaut – jedes Schiff ist ein Unikat. Woher auch immer der Wind weht, die Malö 39 bringt Sie, Ihre Familie und Ihre Freunde schnell und sicher ans Ziel.

Sie ist absolut hochseetüchtig und hat ein kraftvolles Rigg, Rollgenoa und Lattengroßsegel mit Lazy-Jacks. Fast 50% Bleiballast sorgen für ein hohes, aufrichtendes Moment. Die Malö 39 bedeutet komfortables Fahrtensegeln pur. An Deck und unter Deck.



Varje båt byggs individuellt, varje båt är unik. Oavsett väder och vind för Malö 39 er snabbt och säkert till målet. Med sin rullgenoa och storsegel med lazy jacks är Malö 39 enkel att hantera. Med sin högäbarlastandel har Malö 39 en hög stabilitet och är en äkta cruisingbåt, såväl över som under däck.

## Malö 39

LoA:	12.10 m
L. Hull:	11.83 m
LWL:	9.65 m
Beam:	3.76 m
Draft:	1.80 m
Displ.:	8.5 t
Ballast:	3.5 t
Sail Area:	84 m <sup>2</sup>
Engine:	44 kW 62 HP

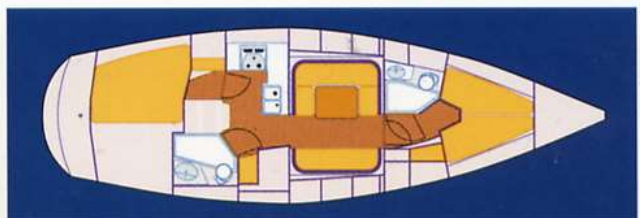
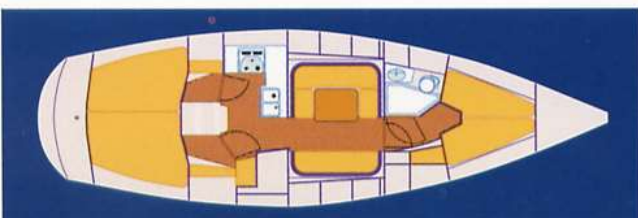

Carefully chosen wood / Erlesene Hölzer / Noggrant utvalt virke



Malö Yachts are one of Scandinavia's oldest, most experienced yachtbuilders. We might not be the biggest yard, but we have always maintained a team of excellent boatbuilders who understand what sailing is all about. On the Malö 39, evidence of this can be found everywhere.

Take a look at the cockpit: it is deep, uncluttered and well protected. The reinforced Targa-arch supporting the mainsheet traveller keeps loose ropes – and heads – out of danger, and serves as the ideal support for grab rails, the spray-hood, cockpit canopy and night illumination.

Stroll over the immaculate hand laid teak deck, feel the security of the Kevlar re-inforced hull notice the intelligent self-stowing anchor arrangement, examine the quality of the clamps, stanchions and other deckware – they are all through-bolted into metal load plates firmly laminated to the hull and deck.



Malö Yachts zählt zu den ältesten Yachtwerften Skandinaviens. Hier arbeitet ein kleines Team hochqualifizierter Bootsbauer, die alle eine ganze Menge vom Segeln verstehen. Beweise dafür finden Sie überall auf der Malö 39.

Sehen Sie sich z.B. das Cockpit an. Es ist tief und geschützt, alles ist funktionell und klar aufgeteilt. Der Großschot-Traveller befindet sich auf dem Malö-typischen Targabügel. Dieser bietet der Crew zusätzlich Schutz und festen Halt. Hier werden auch Sprayhood und Cockpit-Persenning befestigt.

Gehen Sie über das handverlegte Teakdeck und entdecken Sie die aufwendige Ankerhalterung und die kräftige Ankerwinch unter Deck. Alle Winschen, Klampen, Relingstützen usw. sind durch darunterliegende einlamierte Aluminium-Schienen zusätzlich gesichert. Der Rumpf ist mit handaufgelegten Kevlarmatten verstärkt.



Malö Yachts är ett av de äldre båtvarn i Skandinavien. Där arbetar ett litet och mycket kvalificerat team av båtbyggare som alla förstår sig på segling. Det syns överallt på Malö 39 Se t. ex. på sittbrunnen, den är djup, skyddad och funktionell. Storskotskenan sitter helt ur vägen uppe på den Malötypiska targabågen, som bidrar till stöd och skydd för besättningen.

På targabågen fästes även sprayhood och sittbrunnkapell. På det handlagta teakdäcket gläds man åt att ankare och ankarwinch är helt dolda i den stora ankarboxen. Winchar, knapar, mantågsstöttor etc. är säkert infästa med extra förstärkning i form av inlaminerade aluminiumplåtar. Skrovet är ytterligare förstärkt med hanupplagda kevlarmattor.





Stern cabin / Achterkabine / Akterhytt



Shower / Dusche / Dusch



Foreward cabin / Vorschiff / Förpikshytt



There will never be two exactly similar Malö 39s. Every owner can – and does – customise his boat as he needs and desires. We produce individual interior layout suggestions feasible within the hull and deck design. This level of individual boatbuilding is only possible with a small, dedicated team of flexible craftsmen as you find at the Malö yard.

You may now ask what happens to the price of a Malö yacht. We recommend you should contact us. You will be pleasantly surprised how little the customisation of your Malö 39 can cost!



Keine Malö 39 ist genau wie die andere. Jeder Kunde kann seine Wünsche hinsichtlich Innenausbau und Ausrüstung realisieren. Wir erarbeiten gemeinsam individuelle Lösungen, die innerhalb der vorgegebenen Rumpf- und Decksformen möglich sind. Dieses hohe Maß an Einflußnahme bei einer Serienyacht ist nur durch ein kleines, übersichtliches Team engagierter Bootsbauer wie bei Malö Yachts möglich.

Nehmen Sie bitte mit uns Kontakt auf. Sie werden überrascht sein, wie kostengünstig wir Ihre persönlichen Wünsche beim Bau einer Malö 39 erfüllen können.



Ingen Malö 39 är likt den andra, kundernas individuella önskemål tillgodoses, både inrednings- och utrustningsmässigt. Malö Yachts arbetar tillsammans med sina kunder fram lyckade lösningar så långt det är möjligt inom de givna skrov- och däckstrymmena. Detta stora mått av individuell

anpassning på en serieproducerad båt kan endast uppnås med hjälp av erfarna och engagerade båtbyggare, som det finns på Malö Yachts.

Tag gärna kontakt med oss. Ni blir överraskad av hur vi på ett personligt sätt uppfyller Era önskemål om Malö 39.



# Malö 39



Our yard has been in our family's possession for many generations. Grandfather Johannes started building his first wooden yachts about 60 years ago, and our uncle Orvar and father Bo built their first GRP Malö Yacht approximately 30 years ago. Their commitment is our heritage: To build the finest sailing craft for demanding yachtsmen.

Unsere Werft ist seit Generationen in Familienbesitz. Vor etwa 60 Jahren begann Großvater Johannes mit dem Bau hölzerner Segelyachten. Onkel Orvar und Vater Bo Olsson konzipierten und bauten vor etwa 30 Jahren die ersten Malö Yachten mit Kunststoffrumpf. Ihr hoher Anspruch ist unsere Verpflichtung: Der Bau hochwertiger Yachten für Segler, die Geschwindigkeit, Komfort und Sicherheit erwarten.



Malö Yachts är ett familjeföretag i tredje generationen. Farfar Johannes Olsson började bygga segelbåtar i trä för nästan 60 år sedan. Bo och Orvar Olsson skapade Malöbåtarna och byggde sina första glasfiberbåtar för cirka 30 år sedan. Denna tradition förpliktar Bengt och Lars Olsson till att fortsätta att bygga säkra, bekväma och snabba segelbåtar med absolut högsta kvalitet.

*Lars & Bengt Olsson*





The Malö 39: A product of pride and joy, made and tested  
in Kungsviken – the Bay of Kings

Die Malö 39: Mit Stolz und Freude gebaut und getestet  
in Kungsviken – der Bucht der Könige

Malö 39: Byggd och utprovad, med glädje och  
yrkesstolthet, i Kungsviken – Konungarnas vik



**Malö Yachts AB Sweden**

Kungsviken · S-440 90 Henån  
Tel.: +46 (304) 592 20 · Fax: +46 (304) 591 45

**Malö Yachts Deutschland**

Meisenweg 37 · 22926 Ahrensburg · Tel.: 04102 / 52311 · Telefax: 04102 / 1651

**Malö Yachts Benelux**

Súderséleane 13 · 8711 GX Workum · Tel.: 05151 / 42108 · Telefax: 05157 / 9781

**Malö Yachts UK**

Nordic Marine · Salterns Marina · Salterns Way · Lilliput · Poole BH 14 8JR  
Tel.: 0202 / 70 00 89 · Telefax: 0202 / 70.90 72

# **Maiu 39**

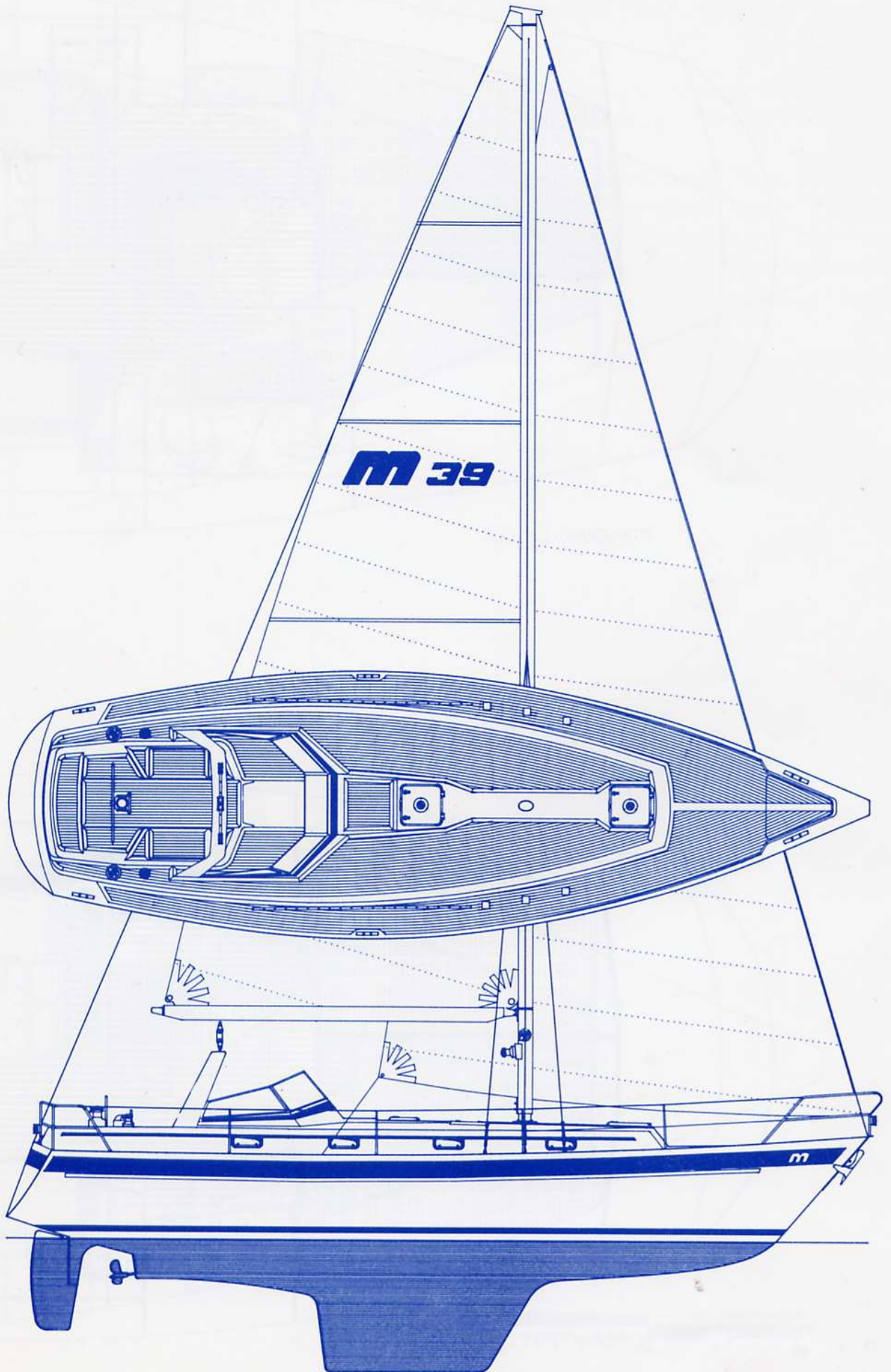

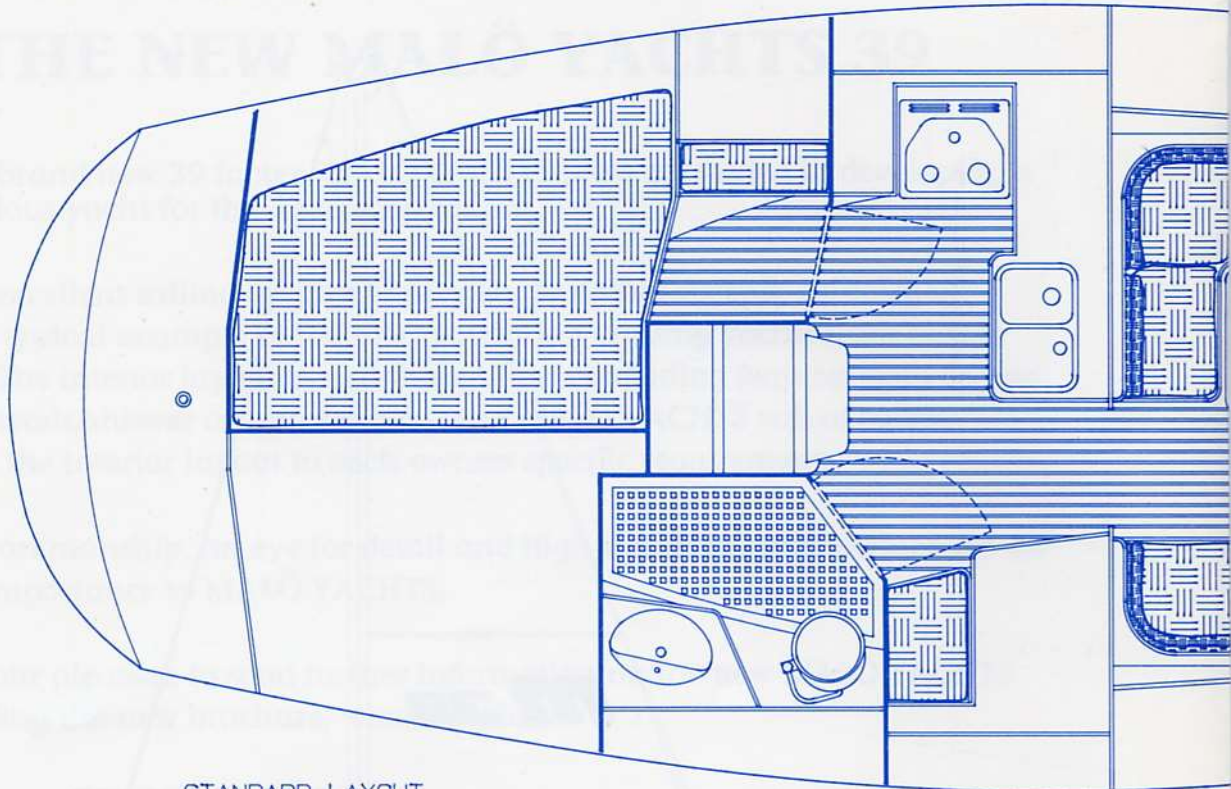

STANDARD LAYOUT

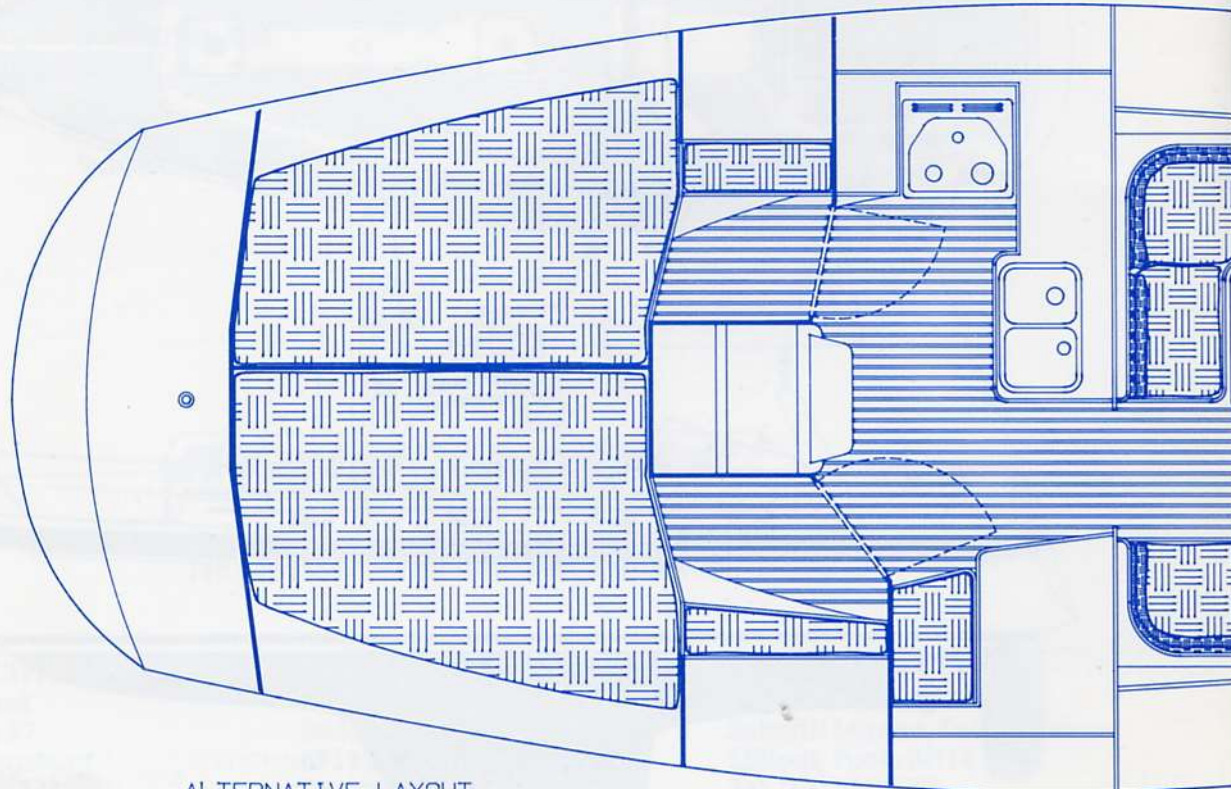

ALTERNATIVE LAYOUT



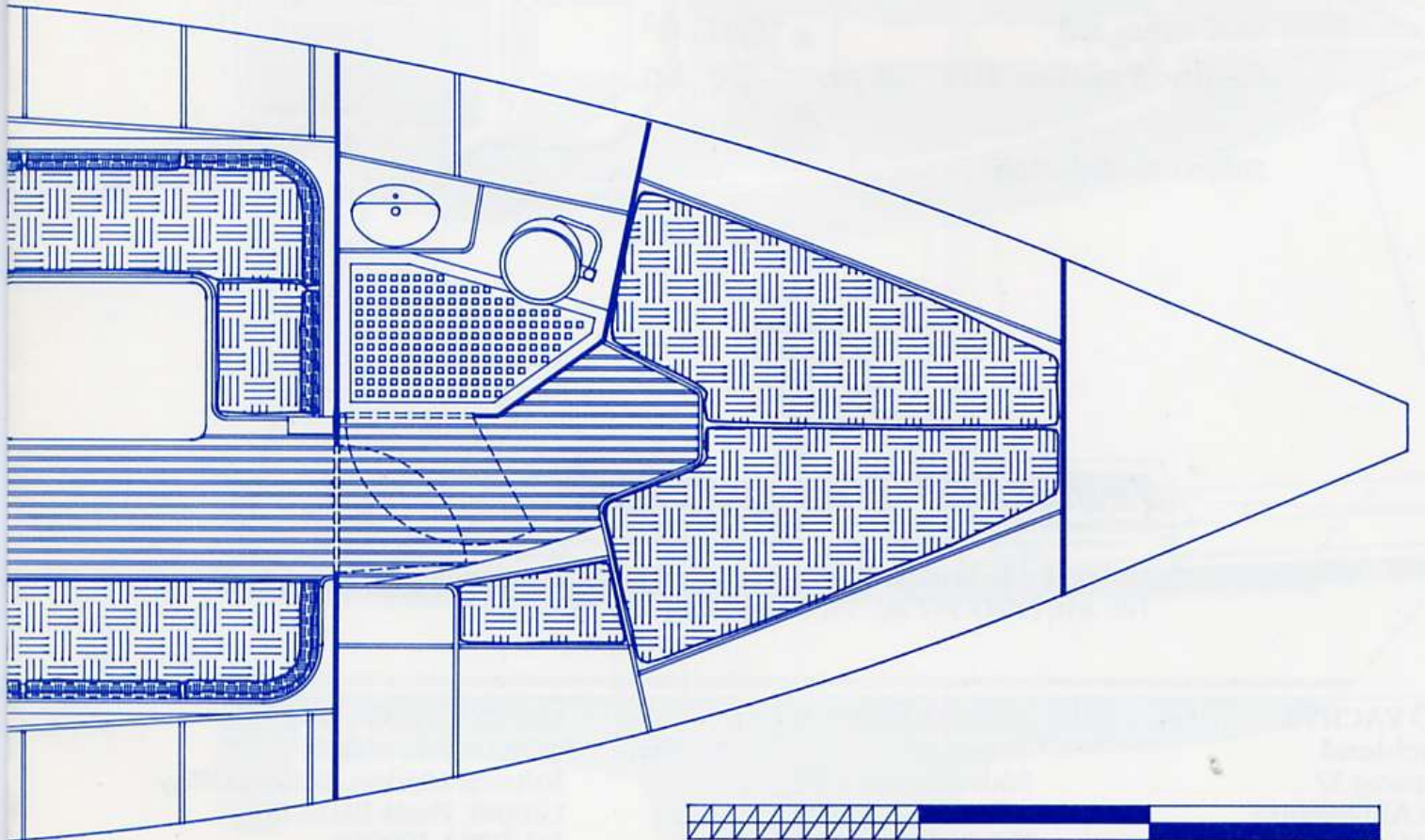
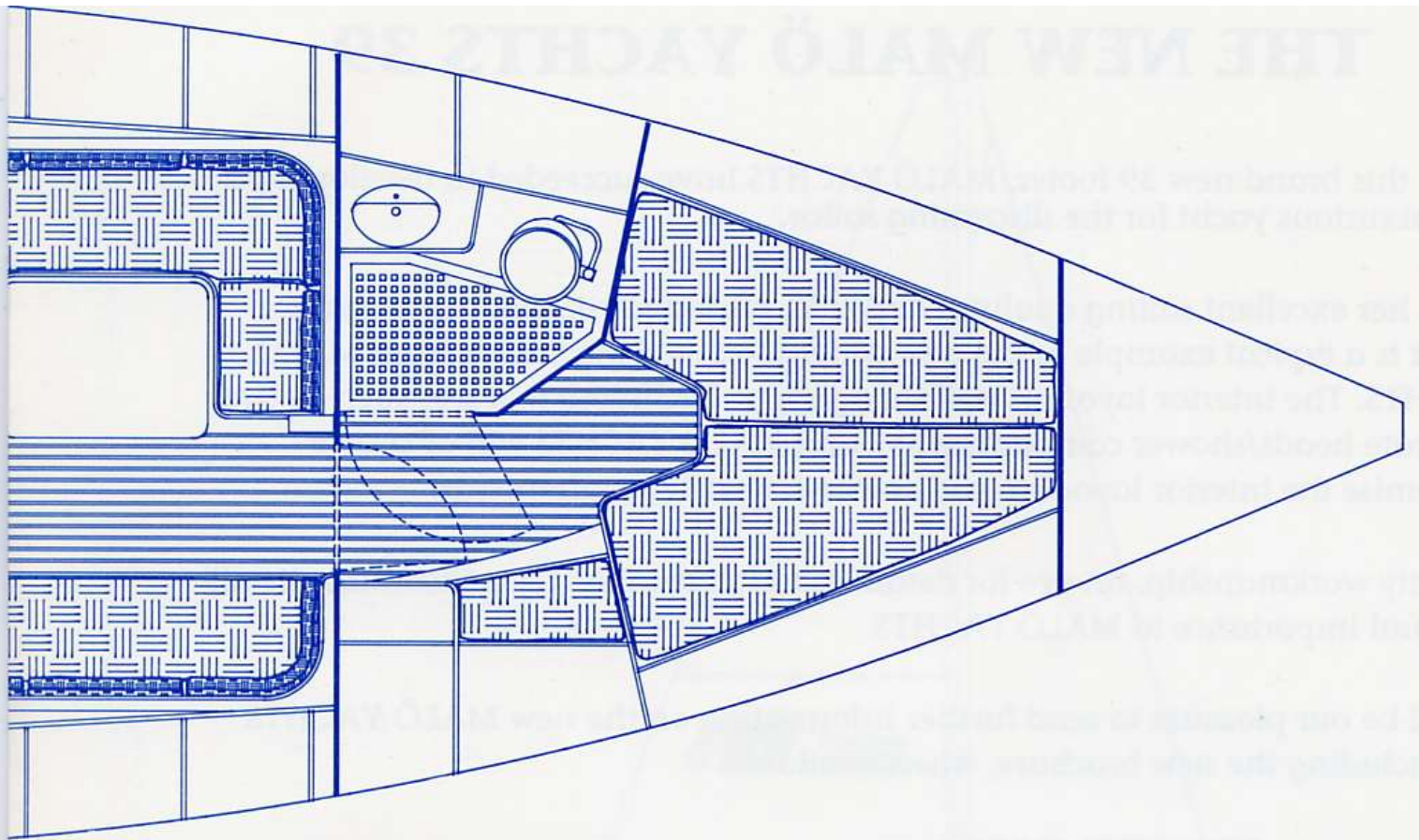

# THE NEW MALÖ YACHTS 39

With this brand new 39 footer, MALÖ YACHTS have succeeded in developing a fast luxurious yacht for the discerning sailor.

With her excellent sailing qualities and safe, protected cockpit, this elegant yacht is a typical example of the new generation cruising yachts from MALÖ YACHTS. The interior layout is well thought out, including features such as two separate heads/shower compartments - and MALÖ YACHTS will of course customise the interior layout to each owners specific requirements.

Quality workmanship, an eye for detail and high standard specifications are all of equal importance to MALÖ YACHTS.

It will be our pleasure to send further information on the new MALÖ YACHTS 39, including the new brochure, when available.

## TECNICAL DATA:

L.o.a.	39' 8"
Hull length	38' 10"
L.w.l.	31' 8"
Beam	12' 2"
Draught	5' 11"
Displacement	18200 lb
Ballast	7700 lb
Sail area, std	820 ft <sup>2</sup>
Engine Yanmar 4JH	appr. 50 hp

Subject to alteration



MALÖ YACHTS AB, Kungsviken, S-440 90 HENÅN, Sweden.  
Tel: +46 (304) 592 20. Fax: +46 (304) 591 45.

MALÖ YACHTS  
Deutschland  
Meisenweg 37  
22926 Ahrensburg  
Tel. 04102/52311  
Fax. 04102/1651

MALÖ YACHTS  
Benelux  
Súderséleane 13  
8711 GX Workum  
Tel. 05151/42108  
Fax. 05157/9781

MALÖ YACHTS UK/  
NORDIC MARINE  
Salterns Marina, Salterns Way  
Lilliput, Poole BH14 8JR  
Tel. 0202-700089  
Fax. 0202-709072